

## WA COMPACT | WELDING SYSTEM

The WA Compact Welding System is an advanced and versatile welding solution designed for making both continuous and stitch butt and fillet welds using the MIG/MAG method.

The system provides efficient joint tracking for active compensation of torch position vertically and horizontally with and without oscillation.

WA Compact supports welding with different oscillation patterns, including straight, triangle, trapezoid, and square, enhancing its adaptability to various welding tasks.

It is ideally suited for industrial applications, providing an efficient and budget-friendly option for workshops and large industrial plants.



### Features and benefits:

- **Advanced Welding Capabilities:** Supports both continuous and stitch welding using MIG/MAG method, ensuring versatility in different welding tasks.
- **Precision and Efficiency:** Equipped with oscillation and joint tracking with motorized vertical slide, maintaining the correct torch position for high-quality welds.
- **Flexible Oscillation Patterns:** Offers various weld paths such as straight, triangle, trapezoid, and square, increasing adaptability to different requirements.
- **User-Friendly Control:** Ergonomic remote control pendant with simple and easy to find control knobs makes adjustments possible without lifting of the operator's welding hood.
- **Custom Track Length:** Track sections consists of 2 m support segments. The total length of the track can be tailored to the customer's requirements.
- **Cost-Effective Solution:** Budget-friendly advanced and versatile welding solution with customized workspace, making it a practical choice for both workshops and large industrial facilities.

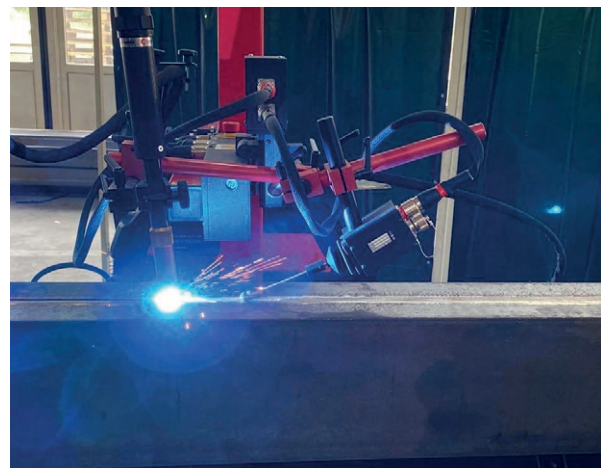

### Welding joints:



## WA COMPACT TECHNICAL SPECIFICATION

Voltage	1~ 110-120 V, 50-60 Hz 1~ 220-240 V, 50-60 Hz
Power	200 W
Torch type	MIG/MAG
MIG/MAG torch diameter	16-22 mm (5/8"-55/64")
Horizontal speed	0,05-2,5 m/min (2-98 inch/min)
Standard torch travel length *	3.5 m
Standard overall track length *	4 m
* Can be extended by a 2 m long track section to maximum 20 m total length	Option
Cable chain in custom lengths on request	Option
Rotating module	Option
Oscillation type	Linear
Weld path	Straight, triangle, trapezoid, square
Oscillation width	0-11,4 cm (0-4 31/64")
Oscillation speed	0,1-2 m/min (4-79 inch/min)
Oscillation dwell time at center and on ends	0-5 s
Maximum oscillator pulling force	50 N
Weight (incl. 4 m standard track length)	484 kg

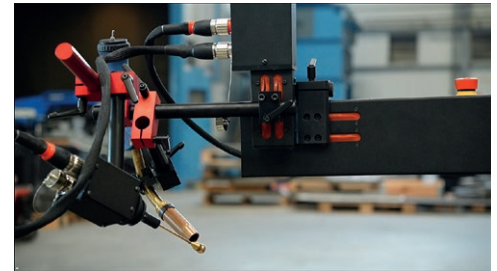

## WA Compact Oscillation Paths



**Triangle.** The machine travels only during oscillation. During oscillation dwell time, the machine stops to fill the crater.



**Trapezoid.** The machine travels at all times, also during oscillation dwell time.



**Square.** The machine travels only during oscillation dwell time in left and right position. During oscillation, the machine stops. During oscillation dwell time in center position the machine fills the crater.

## Standard shipping set:

- Gantry welding system
- 4 m long track (total length up to 20 m on request)
- Arc ignition cable
- Remote control pendant
- Set of 4 signal cables
- Vertical slide
- Tracking sensor
- Fork tracking tip
- Torch holder
- Rod
- Long oscillator holder
- Rod clamp (2 pcs)
- Clamping block (2 pcs)
- 2 mm hex wrench
- 1.5 mm hex wrench
- Operator's manual

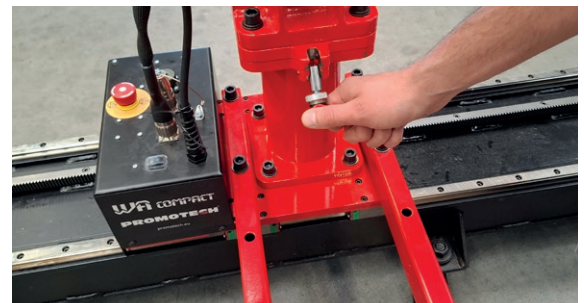
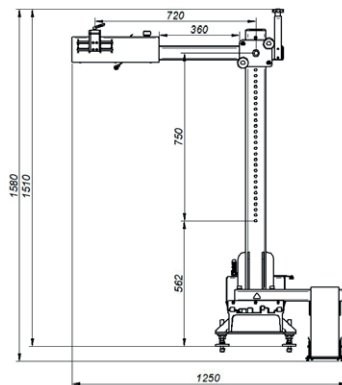

The optional rotating module enables the working arm to be repositioned depending on whether the welded part is on the right or left side of the track, or along the track axis, in order to deliver or collect the workpiece.

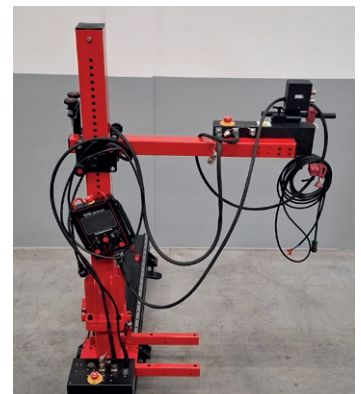

Mitglied im DVS - Deutscher Verband für Schweißen und verwandte Verfahren e. V.



PROMOTECH Sp. z o.o.  
Elewatorska 23/1  
15-620 Białystok, POLAND  
Phone +48 85 678 34 05  
marketing@promotech.eu



Your local dealer:

